

THE CITY OF NAPOLEON

BUILDING & ZONING DEPARTMENT

255 W. RIVERVIEW

(419)592-4010

Building Permit

Permit Number: BP2007-43

Page 1 of 1

Printed: 4/23/2007

ADDRESS:

403 Hudson St.

Applicant

Name: Erie Construction

Address: 4271 Monroe St

Approval Date: 4/23/2007

419-472-4200

Owners

Name: Ms. Rose Botticher

Address: 403 Hudson St

Napoleon, OH 43545

Phone: 419-599-1783

Name: Mr. Jeffrey Mathena

Address: 403 Hudson St

Napoleon, OH 43545

Phone: 419-599-1783

Contractors

Contractor Type: **GENERAL CONTRACTOR**

Name: Erie Construction

Address: 4271 Monroe St

Toledo 43606

Phone: 419-472-4200

Fees and Receipts:

Number	Description	Amount
FEE2007-202	Reroofing/Siding/Gutters (Auto	\$23.00

Total Fees: **\$23.00**

RCPT2007-181 \$23.00

Total Receipts: **\$23.00**

Metal roof

APPLICANTS SIGNATURE: _____

DATE: _____

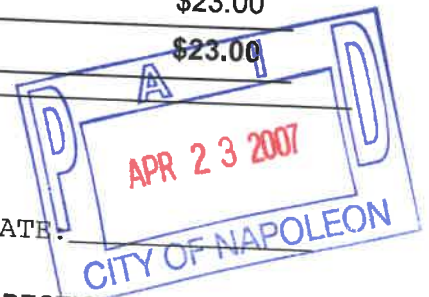

REMINDER: YOU MUST CALL (419)592-4010 FOR AN INSPECTION

CITY OF NAPOLEON GENERAL PERMIT APPLICATION

THIS APPLICATION IS FOR RESIDENTIAL CONSTRUCTION INCLUDING BUILDING, ELECTRICAL, PLUMBING, MECHANICAL, DEMOLITIONS, REMODELING.

DATE: 4/18/07 JOB LOCATION: 403 Hudson St.

OWNER: Rose Botticher
Sesrey Mathena PHONE: 419-599-1783

OWNER ADDRESS: 403 Hudson St. CITY: Napoleon ZIP: 43545

CONTRACTOR: Eric Construction PHONE: 419-380-0146

CONTRACTOR LICENSED WITH THE CITY OF NAPOLEON?: YES: NO:

Is any of this job going to be subcontracted out? Yes: No:

If yes to whom: _____

DESCRIPTION OF WORK TO BE PERFORMED: To Install Eric Metal Roof System / Gutters

PLEASE MARK THE TYPE OF WORK YOU WILL BE PERFORMING

- | | |
|---|--|
| <input type="checkbox"/> A/C ADD ON | <input type="checkbox"/> REMODELING |
| <input type="checkbox"/> BOILER REPLACEMENT | <input checked="" type="checkbox"/> ROOFING |
| <input type="checkbox"/> CURBING | <input type="checkbox"/> SEWER REPAIRS** |
| <input type="checkbox"/> DECKS * | <input type="checkbox"/> SIDEWALK* |
| <input type="checkbox"/> DRIVEWAY* | <input type="checkbox"/> SIDING |
| <input type="checkbox"/> ELECTRICAL SERVICE UPGRADE | <input type="checkbox"/> STORAGE SHED* |
| <input type="checkbox"/> ELECTRICAL SERVICE NEW | <input type="checkbox"/> SWIMMING POOL* |
| <input type="checkbox"/> FENCE* | <input type="checkbox"/> FURNACE REPLACEMENT |
| <input type="checkbox"/> ADDITIONS* | <input type="checkbox"/> TEMP ELECTRIC |
| <input type="checkbox"/> FURNACE NEW | <input type="checkbox"/> WATER TAP (size _____") |
| <input type="checkbox"/> LAWN METER | <input type="checkbox"/> WINDOWS |
| <input type="checkbox"/> PLUMBING | <input type="checkbox"/> ZONING |

*PLEASE INCLUDE A PICTURE SHOWING MEASUREMENTS FROM EXISTING STRUCTURES AND PROPERTY LINES. INDICATING THE TYPE OF WORK YOU WISH TO PERFORM.

** IF WORK REQUIRES GOING INTO THE STREET A STREET BOND IS REQUIRED!

FOR PERMIT COSTS PLEASE FILL OUT REVERSE SIDE.

PERMIT COST WORKSHEET

JOB	BASE FEE	TOTAL
SIDING (only) TOTAL SQ _____ X 1.00 +	\$5.00 =	\$ _____
ROOFING (only) TOTAL SQ <u>166</u> X 1.00 +	\$5.00 =	\$ <u>23.00</u>
WINDOWS (only) # OF WINDOWS _____ X 1.00 +	\$5.00 =	\$ _____
ELECTRICAL # OF CIRCUITS _____ X 3.00 +	\$15.00 =	\$ _____
ELECTRICAL SERVICE UPGRADE	\$15.00 =	\$ _____
PLUMBING (INSIDE) repairs only	\$10.00 =	\$ _____
PLUMBING/SEWER (OUTSIDE)	\$25.00 =	\$ _____
WATER HEATER	\$5.00	\$ _____
SHED UNDER 200 SQ FT	\$ 5.00	\$ _____
FURNACE OR A/C (REPLACEMENT)	\$ 5.00	\$ _____
DEMOLITION (only)	\$30.00	\$ _____
SIDEWALK REPLACEMENT/ NEW	\$25.00	\$ _____
DRIVEWAY	\$25.00	\$ _____

ALL CONSTRUCTION, ALTERATIONS, REMODELING, SHEDS, DECKS & FENCES NOT LISTED ABOVE IS BASED ON COST OF WORK BEING PERFORMED.

COST OF WORK \$ _____ (SEE CHART) \$ _____

0.00	-	250.00	0.00	11,000.00	-	11,999.00	25.00
250.00	-	1,000.00	10.00	12,000.00	-	12,999.00	26.00
1,000.00	-	1,999.00	12.00	13,000.00	-	13,999.00	27.00
2,000.00	-	2,999.00	14.00	14,000.00	-	14,999.00	28.00
3,000.00	-	3,999.00	16.00	15,000.00	-	15,999.00	29.00
4,000.00	-	4,999.00	18.00	16,000.00	-	16,999.00	30.00
5,000.00	-	5,999.00	19.00	17,000.00	-	17,999.00	31.00
6,000.00	-	6,999.00	20.00	18,000.00	-	18,999.00	32.00
7,000.00	-	7,999.00	21.00	19,000.00	-	19,999.00	33.00
8,000.00	-	8,999.00	22.00	20,000.00	-	20,999.00	34.00
9,000.00	-	9,999.00	23.00	21,000.00	-	21,999.00	35.00
10,000.00	-	10,999.00	24.00	22,000.00	-	22,999.00	36.00
				Over 22,999		Please Call	



THIS AGREEMENT made and entered into between Rose-Bolticher + Jeffrey Mathena (OWNER)
 and Erie Construction Mid-West, Inc. who agrees to furnish all labor and material necessary to perform the work hereinafter set forth on the premises. Owner hereby warrants
 that s/he is the owner and holder of the title of the above premises located at:

Address 403 Hudson St City Napoleon OH
 State OH Zip Code 43545 Telephone No. 419-599-1783 County/Township Hemp

Specifications

- customer to ~~tear off~~ * Tear off * roof before install
- 1 Erie to inspect roof decking
 - 2 Erie to install 5 layer underlayment
 - 3 Erie to install proper boots + Flashings
 - 4 Erie to install the Erie stone coated metal roofing system to entire house
 - 5 Erie to install ridge venting
 - 6 Color to be Fawn Grey
 - 7 Erie to install seamless gutter system to entire house color to be Cream - gutter protection to be Musket Brown
 - 8 Erie to install fascia + soffits to entire house to be cream color
 - 9 Job to include all Taxes Warrantys 100% clean up + disposal of Erie's waste not Tear off

PAYMENT TERMS: In consideration of the labor, materials and repair, if any, furnished by said Contractor, the Owner agrees to pay the Contractor.

Contract Price \$ 19537.00 Sales Tax \$ 0 Total Sales Price \$ 19537.00
 Down Payment \$ 250.00 Balance due on completion \$ 19287.00
 If full price for all contract work is not paid in cash, then this Contract is subject to financing approval.

IT IS HEREBY UNDERSTOOD AND AGREED THAT THE UNPAID BALANCE OF CASH PRICE OR THE BANK COMPLETION CERTIFICATE MUST BE PAID TO THE SELLER'S INSTALLER AT THE TIME THE WORK IS COMPLETED.

DEFAULT IN PAYMENT UPON COMPLETION: If I fail to pay the full amount of the UNPAID BALANCE OF CASH PRICE at the time the work is completed, you shall send this Contract and my obligations to your attorney for collection and enforcement for action and collection. If you do so, and only if permitted by applicable state law, I agree to pay, in addition to all other sums due under this Contract and only which may be collected in accordance with applicable state law, reasonable attorney's fees in an amount not exceeding FIFTEEN (15) PERCENT of the unpaid amount then owing, and court costs and fees incurred by you in enforcing this Contract.

DELAYS: I agree that you shall not be liable for delays caused by strikes, weather conditions, and delays in obtaining materials or other causes beyond your control.

NO PAINTING OR STAINING WILL BE DONE BY CONTRACTOR. All wood to be painted or stained by customer.

MATERIALS: The Contractor shall furnish materials for the work and complete the work to be done in a substantial and workmanlike manner. All Workmanship guaranteed for one (1) year only. The undersigned further agree that title in and to any and all materials furnished by Contractor, whether attached to the building or not, shall remain with Contractor until the full amount due from the Owner shall be paid. Windows are not guaranteed against condensation. All unused materials shall, under any conditions, remain the property of Contractor. All material delivered by the Contractor to above premises, shall be stored and safely kept by the Owner and no rental or storage charges therefore shall be made or assessed by Owner. I agree and acknowledge that the windows, woodwork, siding, brick and all other materials removed by you for this installation have no salvage value. When you remove them, you can have them for whatever purpose you want.

ALTERATIONS: Any alteration or deviation from the above specifications involving extra costs will be executed only upon written orders and will become an extra charge.

WARRANTIES: The Contractor shall not be responsible for damage or delay resulting from an Act of God, riots, civil commotions or disorders, delays or defaults by carriers or inherent defects in materials on which work is to be done, strikes, fires, accidents, storms or other causes beyond the reasonable control of contractors. There are no representations, guarantees or warranties, except such as herein incorporated and except manufacturer guarantees, if any, nor any agreements collateral hereto, nor is this contract dependent upon or subject to any condition not herein stated. Any subsequent agreement in reference hereto shall be binding only if in writing and signed by all parties.

CANCELLATION: You may cancel this Agreement or purchase by mailing a written notice to the seller post-marked not later than midnight of the third business day after the date this Agreement was signed. It is agreed that if Owner cancels this Contract AFTER THREE (3) DAYS from date of acceptance and before commencement of work, through no fault of the Contractor, then the liquidated damages arising from costs and expenses necessarily incident to the business of the Contractor in connection with this Contract, shall be a sum equal to 25% of the total contract price, or the actual cost of materials purchased by the Contractor to the date of cancellation, whichever is greater, which sum the Owner undertakes and agrees to pay forthwith. All notices hereunder shall be in writing to the contractor.

HOMEOWNERS INSURANCE: During the period of this Contract, Owner shall keep the above described premises and improvements at all times adequately insured against loss by fire, vandalism and malicious damage, and other hazards customarily insured against under the same circumstances, in a reliable insurance company, such insurance payable to parties having an insurable interest in said premises as their interest may appear.

ARBITRATION: In the event any dispute shall arise between the parties to this Contract as to the respective duties, right and liabilities, there under, it is hereby agreed that such disputes shall be referred to the Better Business Bureau of Toledo, Inc. for arbitration, and the decision of the arbitrators shall be final and binding on said parties. Verbal understandings and agreements with representative shall not be binding.

COMPANY APPROVAL: This Contract is subject to written approval by an officer of the Contractor Company. Said written approval will not be necessary if work is actually commenced by the Contractor.

PERMISSION TO MAKE UNSOLICITED CALLS: You will be contacted from time to time to arrange installation, anniversary service inspections, and future specials and promotions. To comply with all FCC requirements: I/we agree to authorize Erie Construction Mid-West, Inc. to make unsolicited telephone calls to me/us at (419-599-1783) I would like to learn about special offers and information via my e-mail address which is _____

Signature of [Signature] Date 3 Month 7 Year 07
 Owners acknowledge receipt of True Copy of this Contract. IN WITNESS WHEREOF, the Owner and the Contractor have caused these presents to be signed this _____
 By [Signature] Sales Representative
 By [Signature] Owner
 By _____ Corporate Approval
[Signature] Owner

P

ROOF PAYROLL PREP SHEET

Name <i>Jeffrey Mathews</i>	Rose Battichen	Home Phone <i>419-599-1783</i>	Job No. <i>Orange 2 Metal off</i>
Address <i>403 Hudson St</i>		Work Phone <i>419-599-1783</i>	City <i>Toledo</i>
City/State/Zip <i>Nepoleon OH 43445</i>		Work Phone	Inspected By

Roof Load SF

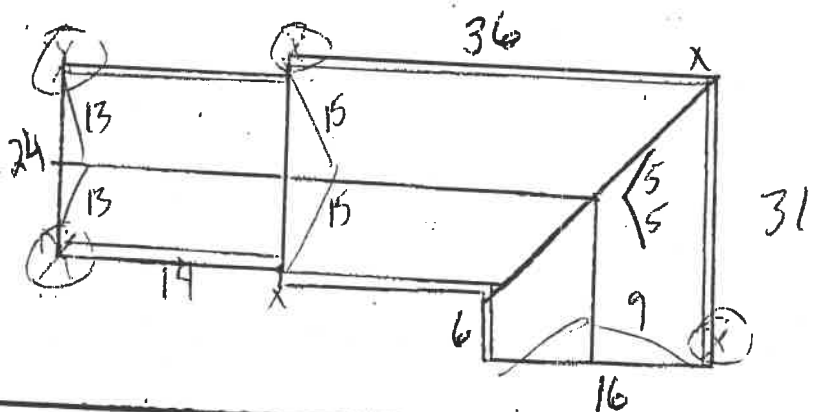

# of Squares <i>17</i>	Shingle Mfr. <i>Decra</i>	Model <i>Stone Coated</i>	Color <i>Fawn Green</i>
---------------------------	------------------------------	------------------------------	----------------------------

# of Layers on Existing Roof <u>2</u>	Remove-Reshingle <input type="checkbox"/>	# of Squares	
# of Squares <i>17</i> (18)	Roof-Over Reshingle <input type="checkbox"/>	# of Squares	<i>17</i> (18) MH
12" of Blown in Insulation	Remove, Resheet, Reshingle <input type="checkbox"/>	# of Squares	
# Ft. New Metal Fascia + Soffit <i>124</i> (cream)	# of Square Feet	# of Dumpsters	
# Ft. of New Fascia Board	Ridge Vent # of Ft.	Remove Existing Gutters	
# of Chimneys	# Feet of Flashing	# Ft. New Gutters <i>120</i> (cream)	
		<i>w/ Leaf Slagger (Masket Brown)</i>	

120 FT GUTTER + SLUGGER
90 FT DOWNSPOUTS (6-1ST FLOOR)

Addendum to Work Order

Customer Rose Botticher & Jeff Mathew Address 403 Hickson St.
 City Napoleon State OH Zip Code 43545 Phone (419) 599-1783
 Erie Construction Office Toledo Original Contract Date 4-6-07

Buyer agrees to purchase the following described goods and services which are to be furnished as a part of the contract referred to above, or, Buyer requests that Seller make the following changes in such contract, previously executed by the parties hereto, subject to all the terms and conditions contained therein, except as otherwise stated herein:

*** Color Change ***

Color of soffits	to be	Warm Sandalwood
Gutters	''	Warm Sandalwood
Facade	''	Warm Sandalwood
Leaf Slugger	''	Brown

Notice to buyer(s) 1) You are entitled to an exact copy of the addendum you sign 2) This addendum cannot be used if the purchase price of the merchandise you bought is changing on this document.

Buyer Signature

Date

Go-Buyer Signature

Date

Erie Construction Representative

Date

